

# X20-7512 V8.0 Technical Specification

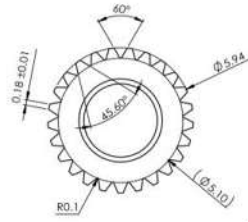

25T

25T 6mm Output Shaft Spline

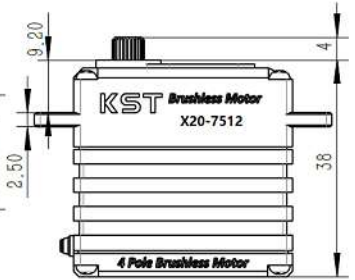
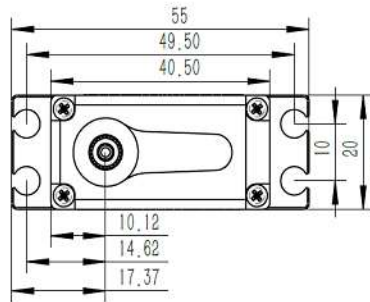

## 1. Operating Data

Rated Voltage	DC7.4V
Voltage Range	DC6.0V-8.4V
Stalling Torque	65Kgf.cm@6.0V
	75Kgf.cm@7.4V
	82Kgf.cm@8.4V
Speed	0.14sec/60°@6.0V
	0.12sec/60°@7.4V
	0.11sec/60°@8.4V
Stalling Current	8.80A@6.0V
	10.8A@7.4V
	12.3A@8.4V
Working Frequency	1520us/333Hz
Default Travel Angle	±50° =100° Total
Temperature Range	-20°C .....+65 °C
Programable	Yes
Case Material	Aluminum Alloy
Motor Type	4 Pole Brushless DC Motor
Gear Set Material	Hardened Steel
Position Sensor	Potentiometer
Ball Bearing	2BB
Waterproof	IP65
Case Dimensions	40.5mm*20mm*38mm±0.2mm
Weight	70g±10%

## 2. Performance

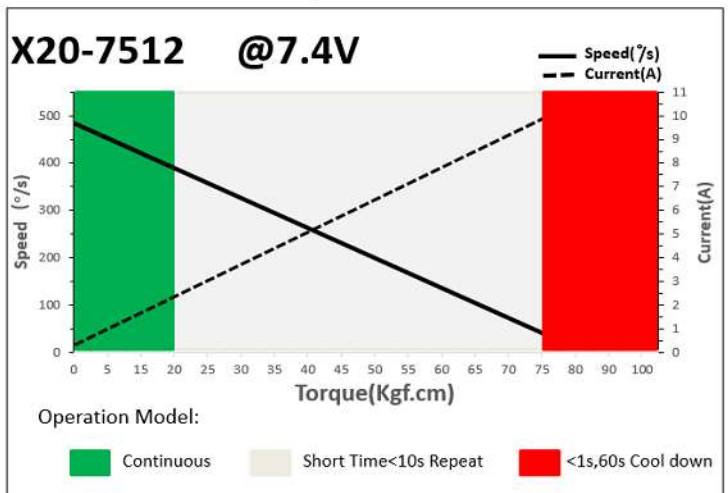

## 3. Command signal

### PWM Command Interface

Signal Voltage	HIGH: min.3.3V, max.5.0V Low: min.0.0V, max.1.5V
Pulse Lengths	900us-2100us
Pulse Lengths for Position -50°/0°/+50°	1000us/1500us/2000us

## 4. Electrical Connection

		Pin Assignment	
	1	Black (White mark)	Signal PWM Command
	2	Black	DC+ Supply Voltage
	3	Black	DC- Supply Ground