

X15-855X V3.0 Technical Specification

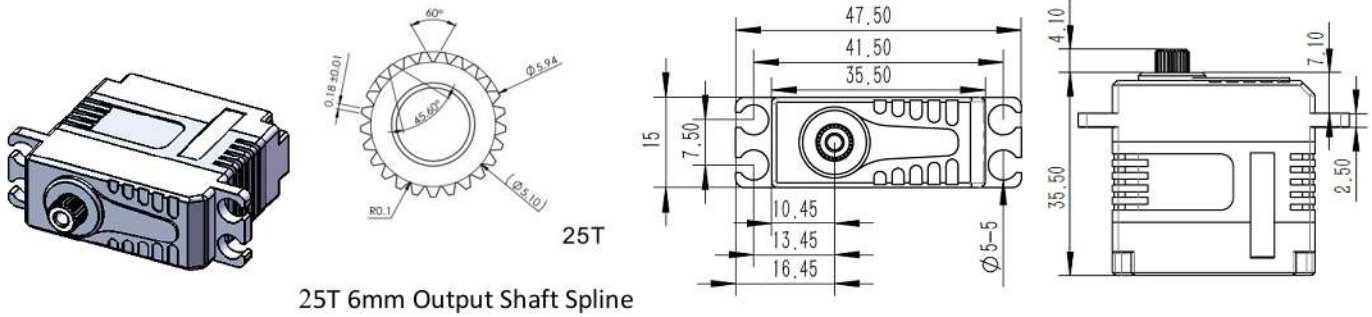

25T 6mm Output Shaft Spline

1. Operating Data

	X15-855X
Rated Voltage	DC7.4V
Voltage Range	DC6.0V-8.4V
Torque	1.0N.m@6.0V
	1.3N.m@7.4V
	1.5N.m@8.4V
Speed	0.07sec/60°@6.0V
	0.06sec/60°@7.4V
	0.05sec/60°@8.4V
Working Frequency	760us/560Hz
Temperature Range	-10℃.....+65℃
Case Material	Aluminum Alloy
Motor Type	Brushless DC Motor
Gear Set Material	Hardened Steel
Position Sensor	Potentiometer
Ball Bearing	2BB
Case Dimensions	35.5mm*15mm*35.5mm±0.2mm
Weight	45g±10%

28g

2. Performance

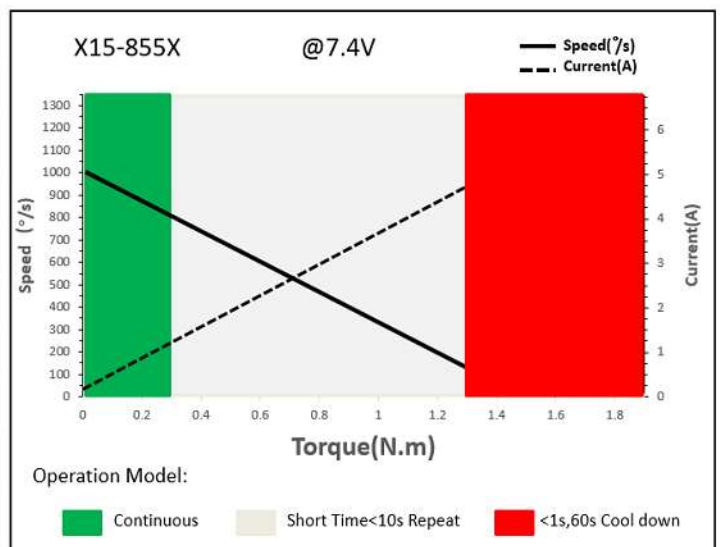

3. Command signal

PWM Command Interface

Signal Voltage	HIGH: min.3.3V, max.5.0V Low: min.0.0V, max.1.5V
Pulse Lengths	450us-1050us
Working Frequency	760us/560Hz

4. Electrical Connection

<p>3 2 1</p>	Pin Assignment			
	1	Orange	Signal	PWM Command
	2	Red	DC+	Supply Voltage
	3	Brown	DC-	Supply Ground