

BLS815 v2.0

Technical Specification

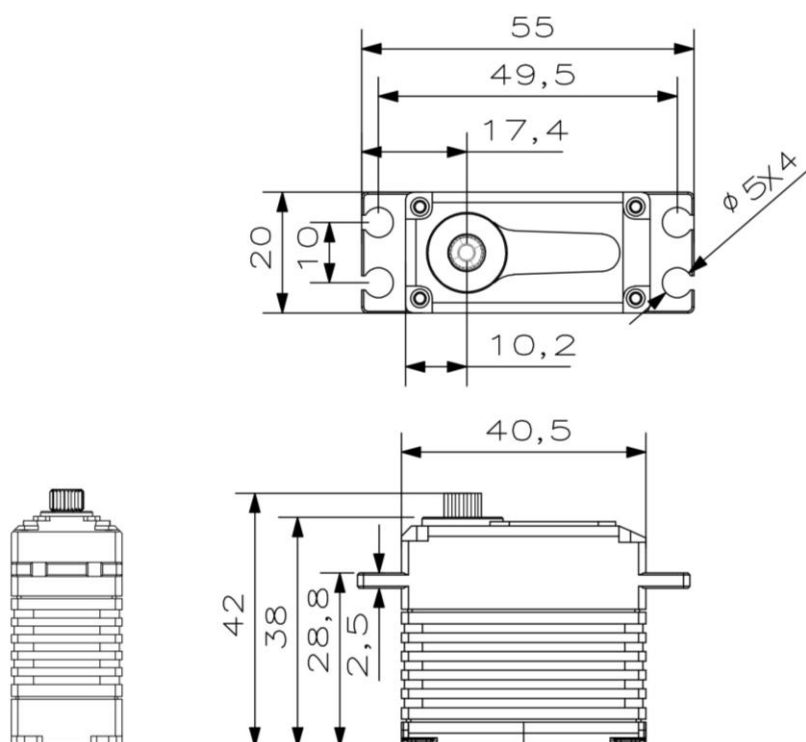
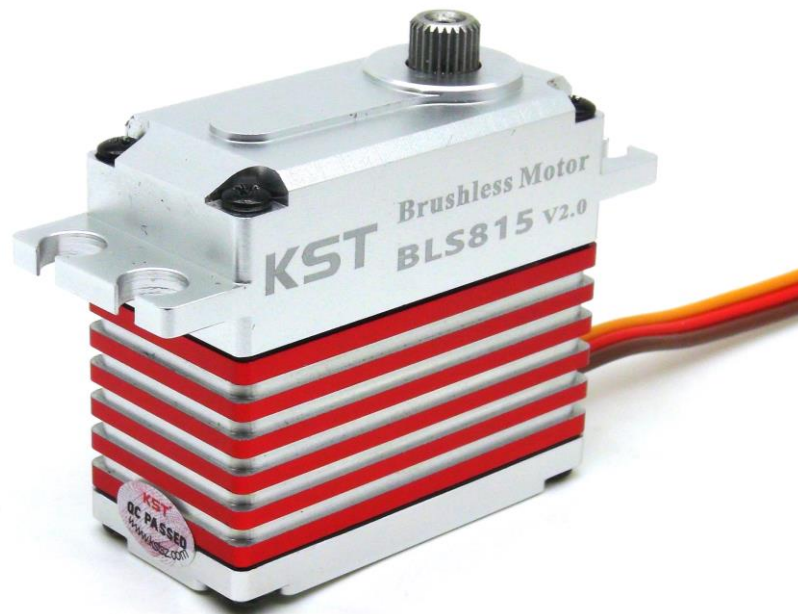

Operating Data

| | BLS815 v2.0 |
|------------------------------------|------------------------|
| Operation Voltage(rated) | DC7.4V |
| Operation Voltage Range | DC6V-8.4V |
| Torque | 14kg.cm@6.0V |
| | 17Kg.cm@7.4V |
| | 20Kg.cm@8.4V |
| Speed | 0.09sec/60 °@6.0V |
| | 0.08sec/60 °@7.4V |
| | 0.07sec/60 °@8.4V |
| Travel Angle | ± 50° when 1000-2000us |
| Operating Temperature Range | -10℃……+65℃ |

Performance

BLS815 V2.0

@7.4V

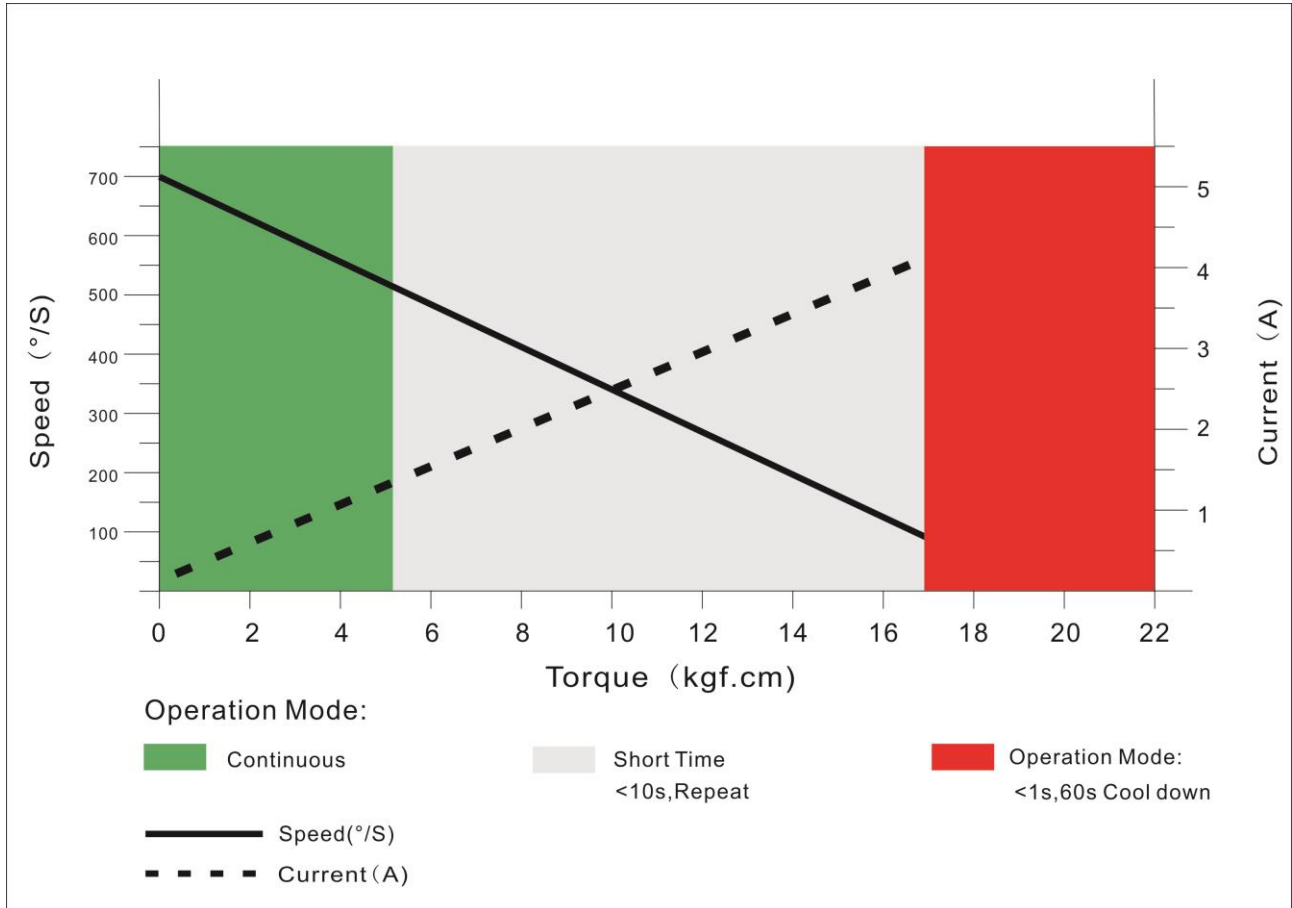

PWM Command Signal

| PWM | BLS815 V2.0 |
|---|---|
| Signal Voltage | TTL-Level: HIGH:min.3.3V,max.5.0V TTL-Level: Low:min.0.0V,max.0.5V |
| Pulse Lengths | 900-2100us |
| Pulse Lengths for Position -50° /center/ $+50^{\circ}$ | 1000us/1500us/2000us |
| Resolution | <2us |

Materials and protective features

| | |
|---------------------------|----------------|
| Case Material | Aluminum Alloy |
| Splash Surface Treatment | |
| Salt Water Resistance | |
| EMI/RFI Shielding | |
| Motor Type | Brushless |
| Gear Set Material | Hardened steel |
| Position Sensor | Potionmeter |
| Position Feedback | Optional |
| Shielded Connecting Cable | 22AWG |

Dimensions

| | |
|-----------------|--------------|
| Case Dimensions | 40.5*20*38mm |
| Weight | 70g |