

BLS915 V8.0

Technical Specification

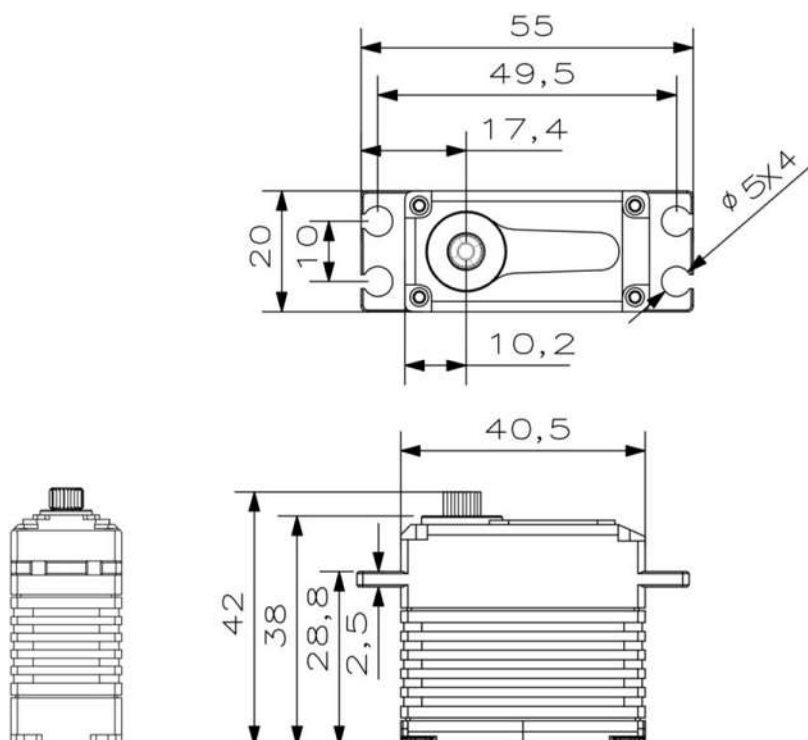

Operating Data

	BLS915 V2.0
Operation Voltage(rated)	DC7.4V
Operation Voltage Range	DC6V-8.4V
Torque	18kg.cm@6.0V
	22Kg.cm@7.4V
	25Kg.cm@8.4V
Speed	0.09sec/60°@6.0V
	0.08sec/60°@7.4V
	0.07sec/60°@8.4V
Travel Angle	± 50° when 1000-2000us
Operating Temperature Range	-20℃……+65℃

Performance

BLS915 V2.0

@7.4V

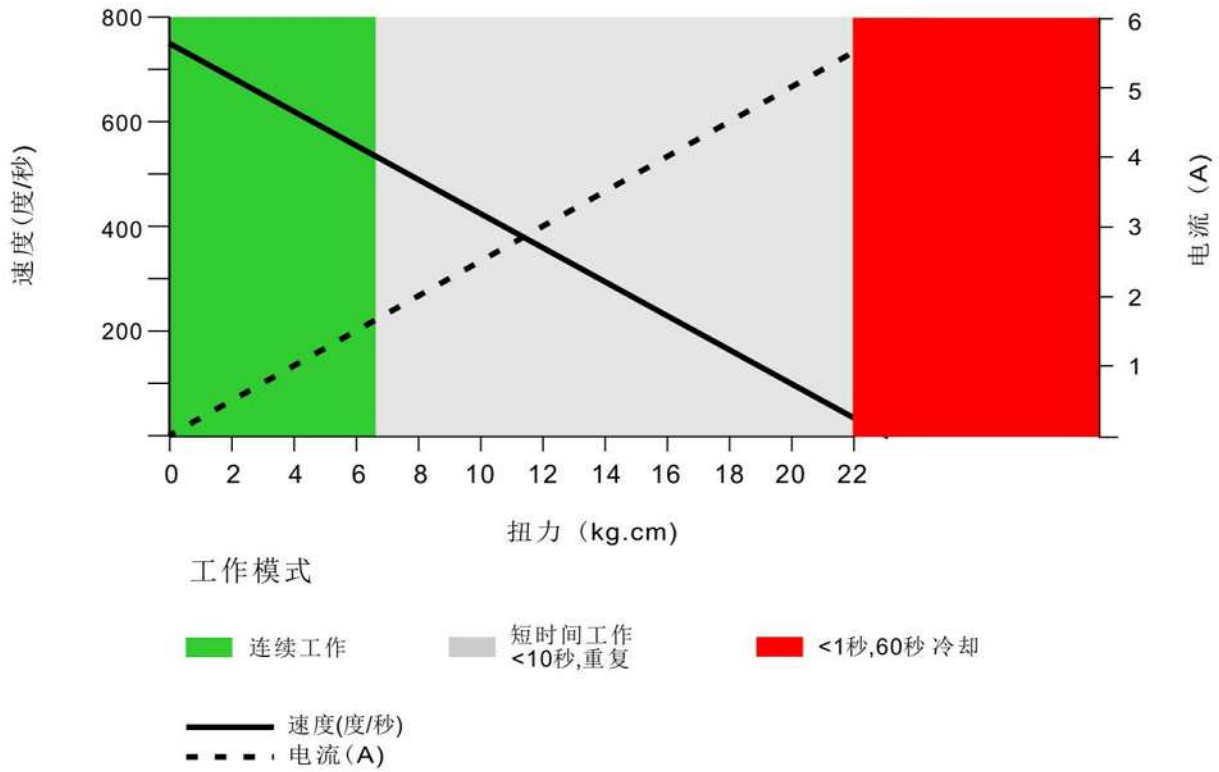

PWM Command Signal

PWM	BLS915 V2.0
Signal Voltage	TTL-Level: HIGH:min.3.3V,max.5.0V TTL-Level: Low:min.0.0V,max.0.5V
Pulse Lengths	900-2100us
Pulse Lengths for Position -50° /center/ $+50^{\circ}$	1000us/1500us/2000us
Resolution	$\leq 2\mu\text{s}$

Materials and protective features

Case Material	Aluminum Alloy
Motor Type	Brushless
Gear Set Material	Hardened steel
Position Sensor	Potentiometer
Position Feedback	Optional
Connecting Cable	22AWG

Dimensions

Case Dimensions	40.5*20*38mm
Weight	78g